



Bulletin #: SB049
 Author: Richard Waters
 Rev: A
 Date: 10/22/2002
 Affected Models: Chief 2002
 Engine Serial #:

Service Bulletin

Flywheel Oil Passage-way check

Service Kit

Part #	Part Description	Qty
	Non Required	

Tools Required

3/8" Drive Ratchet, 1/8" hex bit, 3/16" hex bit

Materials Required

Small oil can (pump type)

Caution

Read these instructions carefully and thoroughly before commencing work. If you do not understand the instructions or have questions, see your supervisor. If you are unsure of any of the procedures, please contact your Indian Field Warranty Representative (FWR).

Description

The objective of these instructions is to establish whether oil is travelling freely from the oil passage-ways in the cam cover assembly, through the passage-ways in pinion shaft and fly wheel to the crank pin bearings.

The most likely cause of a blockage is the misalignment of oil passage-ways between the pinion shaft and fly wheel or the fly wheel and crank pin.

Blocked or misaligned oil passage-ways will result in oil not reaching the crank pin bearings causing component failure.

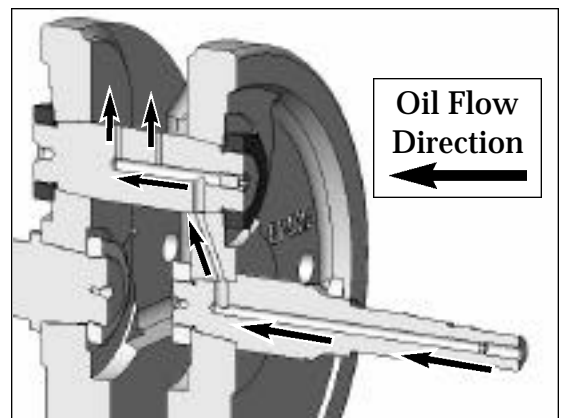

Preparation

- 1 Place a drain pan below the cam cover.
- 2 Using a 3/16" hex bit, remove the 2 ignition cover bolts. Remove the ignition cover and gasket.
- 3 Using a 1/8" hex bit, remove the button head bolt and ignition rotor.
- 4 Using a 3/16" hex bit, remove the 2 allen head bolts securing the outer cam cover.
- 5 Using a 3/16" hex bit, remove 7 allen head bolts securing the cam cover assembly. Leave the bottom bolt (A) in place .

Note the different lengths of the 7 cam cover assembly bolts and the 2 outer cam cover bolts.

- 6 Remove the outer cam cover, seal and three O-rings. Inspect the seal and O-ring and replace if worn or damaged. Wipe off excess oil.

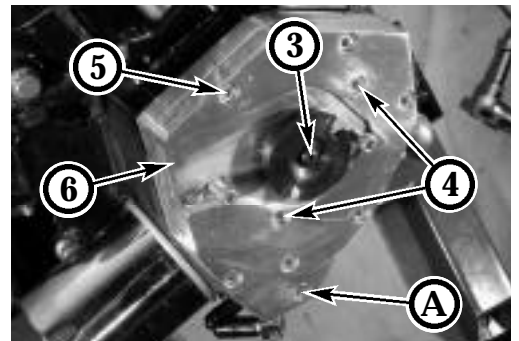
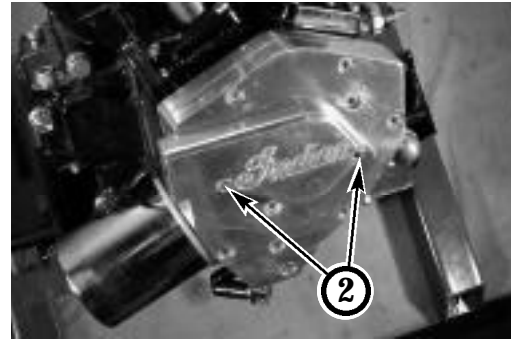

Inspection

- 7 Using a small oil can, pump oil at least 5 times into the oil passage-way in the center of the pinion shaft.
NOTE: Hold the nozzle of the oil can firmly over the hole to create a good seal.
- 8 Oil should pump freely into the pinion shaft. Oil leaking back around the oil can's nozzle will indicate a blocked oil passage-way.

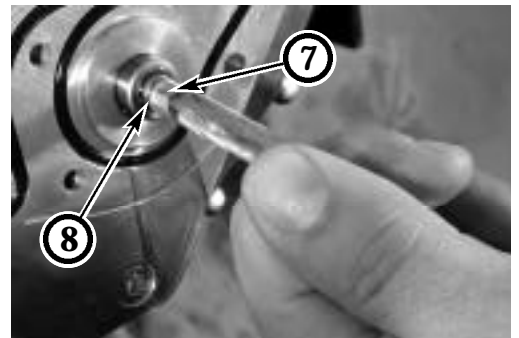

Action

A blocked/misaligned oil passage-way may require an engine swap. Contact your Indian Field Warranty Representative (FWR) immediately for further action.

Refit

- 9 Lubricate the 3 O-rings and refit into the grooves on the inner cam cover.

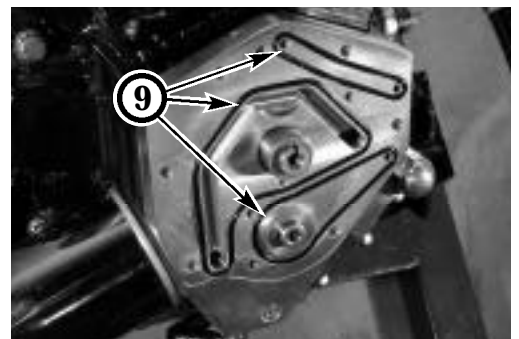

10 Lubricate both sides of the cam seal with grease and refit both the outer cam cover and seal to the inner cam cover.

11 Clean the 2 outer cam cover bolts (shorter bolts), apply Blue Loctite 242 to the first 4 threads and secure the outer cam cover. Tighten to 120inch/lbs.

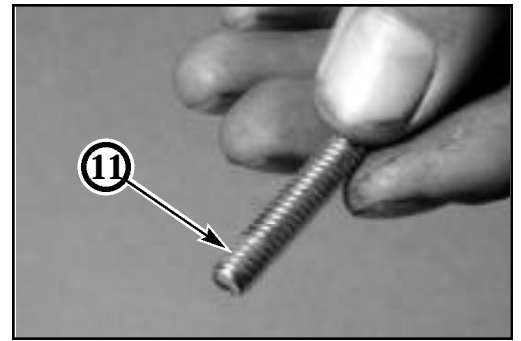

12 Clean the 7 cam cover bolts, apply Blue Loctite 242 to the first 4 threads and secure the cam cover assembly. Tighten to 120inch/lbs.

13 Refit the ignition rotor by aligning the pin in the rotor to the slot in the cam shaft.

14 Clean the rotor bolt, apply Blue Loctite 242 to the first 4 threads and secure the rotor hand tight.

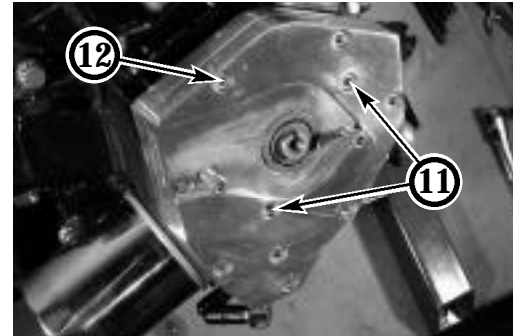

15 To identify engines that have completed this inspection mark the outer cam cover 1/2" above the LH trigger housing bolt with a center punch.

16 Refit the ignition cover.

17 Clean the 2 ignition cover bolts, apply Blue Loctite 242 to the first 4 threads and tighten to 84inch/lbs.

